

# Single-Ended Encoder with Index Channel

FEATURES

- Small Size, Pre-Mounted to Dual Shaft Motor
- 50 to 1,250 Cycles Per Revolution (CPR)
- Tracks 0 to 100,000 Cycles Per Second
- 2-Channel Quadrature TTL Squarewave Outputs
- Third Index Channel
- Allows + / - .010" Axial Shaft Play
- Powered From a Single +5VDC Power Supply
- Operating Temperature of -40° to +100° C
- RoHS Compliant and REACH Certified



DESCRIPTION

### New Optical Encoder Module:

This new transmissive optical encoder module was designed to be an improved replacement for the Avago HEDS-9000 series encoder module. This module is designed to detect rotary position when used with a code wheel. The new module consists of a lensed LED source and a monolithic detector IC enclosed in a small polymer package. The new module uses phased array detector technology to provide superior performance and greater tolerances over traditional aperture mask type encoders. The new module provides digital A & B quadrature outputs with an optional third output index channel. Each module is resolution specific and is matched to the resolution of a code wheel. All standard resolutions offered by the HEDS-9000 series encoder module, as well as additional resolutions, are now supported by the new module. The new module operates with a single 5V supply and provides single ended outputs which are capable of both sinking and sourcing 8mA at TTL levels. An internal 0.1 uF decoupling capacitor is designed into the new module to provide enhanced noise immunity over the HEDS-9000 series encoder modules. Physically, the new module has no external wire loops which can interfere when mounting. The connector pins are 0.051" shorter than HEDS modules, while still providing .30" insertion depth.

When these Single-Ended Encoders with Index are attached to the end of an Anaheim Automation dual shaft motor, provide digital quadrature output. The squarewave output provide digital feedback for applications that require position and/or speed control.

To order an single-ended encoder with index, add a " - ", the CPR number, and an SI on the end of any Anaheim Automation dual shaft motor.

# 23Y106D-LW8-1000SI

CPR		
0050	0256	0720
0096	0360	0900
0100	0400	1000
0192	0500	1024
0200	0512	1250
0250	0540	

Example: The part number for a 1000 CPR encoder mounted on a 23Y106D-LW8 stepper motor would be 23Y106D-LW8-1000SI.

DIMENSIONS AND PINOUTS

L010390

**DEFAULT OPTION:**

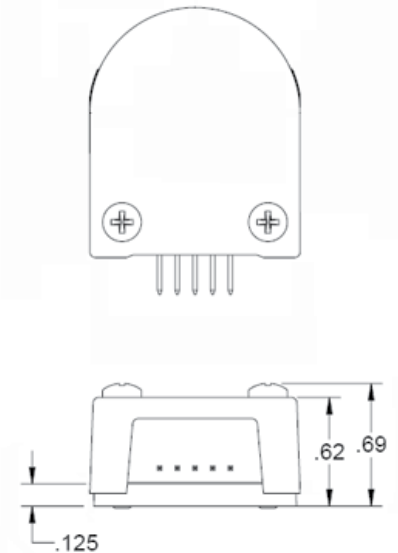
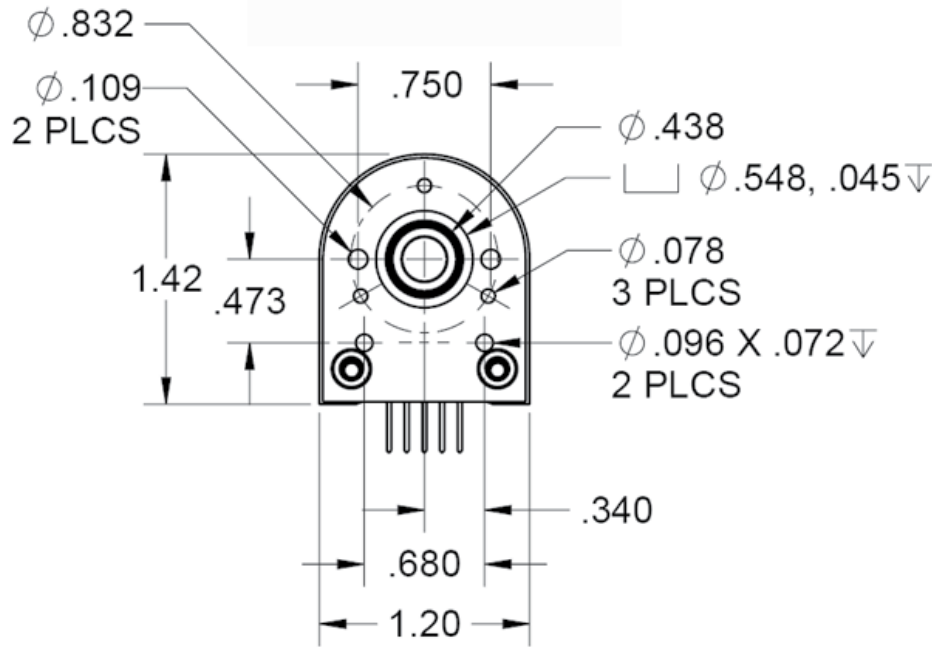

Note: All dimensions are in inches

**SINGLE-END ENCODER TIMING DIAGRAMS**

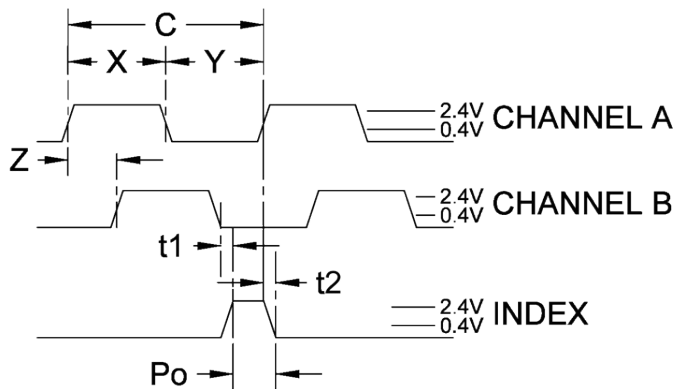

**ROTATION:**  
CW - A LEADS B, CCW - B LEADS A

**SINGLE-ENDED ENCODER PINOUT**  
TOP OF ENCODER FACING PLUG

Pin #	Function
1	Ground
2	Index
3	Channel A
4	+5VDC Input
5	Channel B

Model #	Description
CPR(N):	The Number of Cycles Per Revolution
One Shaft Rotation:	360 mechanical degrees, N cycles
One Electrical Degree (°e):	1/360th of one cycle
One Cycle (C):	360 electrical degrees (°e). Each cycle can be decoded into 1 or 4 codes, referred to as X1 or X4 resolution multiplication
Symmetry:	A measure of the relationship between (X) and (Y) in electrical degrees, nominally 180 °e
Quadrature (Z):	The phase lag or lead between channels A and B in electrical degrees, nominally 90 °e
Index (CH I):	The Index Output goes high once per revolution, coincident with the low states of channels A and B, nominally 1/4 of one cycle (90°e)

Recommended Operating Conditions	Min	Max	Units
Temperature	-40	100	°C
Load Capacitance	-	100	pF
Count Frequency	-	100	kHz
Count Frequency	0	360	kHz

Parameter	Max	Units
Vibration (5 to 2kHz)	20	g
Shaft Axial Play	+/- 0.01	in.
Shaft Eccentricity Plus Radial Play	0.004	in.
Acceleration	250,000	rad/sec <sup>2</sup>

## Cables:

The following cables are compatible with Anaheim Automation's single-ended series encoder with index. Select a cable length from the table below:

Cable Part Number	Length
ENC-CBL-AA4032	1 ft.
ENC-CBL-AA4032-04	4 ft.
ENC-CBL-AA4032-10	10 ft.

*NOTE: For pricing and other information on cables and centering tools, please visit Accessories on our website.*

Parameter	Min	Typ	Max	Units
<b>Supply Voltage</b>	4.5	5.0	5.5	Volts
<b>Supply Current</b>	-	27	30	mA
CPR < 500, no load	-	55	57	mA
CPR ≥ 500, no load	-	72	85	mA
<b>Output Low</b> (I <sub>OL</sub> = 8mA max)	-	-	0.5	Volts
<b>Output High</b> I <sub>OH</sub> = -8mA max no load	2.0 4.2	- 4.8	- -	Volts Volts
<b>Output Current Per Channel</b>	-8.0	-	8.0	mA
<b>Output Current Per Channel</b>	-5	-	5	mA
<b>Output Rise Time</b>	-	110	-	nS

\* Unloaded high level output voltage is 4.80V typically, 4.2V minimum.

Timing Characteristics	Symbol	Min	Typ	Max	Units
Cycle Error	C	-	3.0	5.5	°e
Symmetry	X,Y	150	180	210	°e
Quadrature	Z	60	90	120	°e
Index Pulse Width	Po	60	90	120	°e
Ch. I Rise After Ch. B or Ch. A Fall	t1	10	100	250	ns
Ch. I Fall After Ch. B or Ch. A Rise	t2	70	150	300	ns